

DUCTILE IRON EPOXY Y-STRAINER PN16

Model: DI-YS-PN16

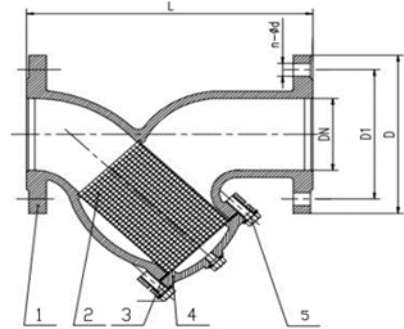

TECHNICAL DATA

SPECIFICATION STANDARDS

Design according to: DIN3202-F1
Face to face standard: DIN3202-F1
Flange end standard: BS4504 PN16
Inspection and testing standard: ISO 5208
Nominal pressure: 1.6 MPa
Test pressure shell: 2.4 MPa
Test pressure seal: 1.76 MPa
Working temperature: Max 80°C
Applicable medium: Water

STANDARD MATERIALS OF MAIN PARTS

ITEM	PART NAME	MATERIAL
1	BODY	DUCTILE IRON
2	SCREEM	SS304
3	GASKET	RUBBER
4	BONNET	DUCTILE IRON
5	BOLT	CACBON STEEL

Mesh Hole Dimension

SIZE	Hole Diameter
DN50-DN100	2mm
DN125-DN150	3mm
DN200-DN300	4mm

DIMENSION (mm)

DN	L	D	D1	n-ød
DN50	230	165	125	4-ø19
DN65	290	185	145	4-ø19
DN80	310	200	160	8-ø19
DN100	350	220	180	8-ø19
DN125	400	250	210	8-ø19
DN150	480	285	240	8-ø23
DN200	600	340	295	12-ø23
DN250	730	405	355	12-ø28
DN300	850	460	410	12-ø28
DN350	980	520	470	16-ø28
DN400	1100	580	525	16-ø31
DN450	1200	640	585	20-ø31
DN500	1250	715	650	20-ø34