

CAST STEEL Y-STRAINER FLANGE END PN16

Model: ARV-205FE(D)-PN16

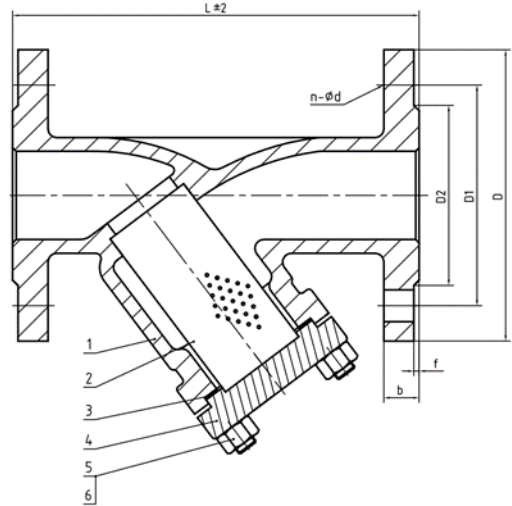

TECHNICAL DATA

SPECIFICATION STANDARDS

Design according to: EN 12516
Face to face dimension: EN 558
Flange end standard: EN 1092-1 PN16 (DIN PN16)
Inspection and testing standard: EN 12266
Nominal pressure: 1.6 MPa
Test pressure shell: 2.4 MPa
Test pressure seal: 1.76 MPa
Working temperature: Max 425°C
Applicable medium: Water, Steam, Oil, ETC...

STANDARD MATERIALS OF MAIN PARTS

ITEM	PART NAME	MATERIAL
1	BODY	CAST STEEL (GS-C25/ 1.0619)
2	SCREEN	SS304
3	GASKET	304+GRAPHITE
4	BONNET	CAST STEEL
5	BOLT	A193-B7
6	NUT	A194-2H

DIMENSION (mm)

DN	L	D	D1	D2	b	f	n-∅d
DN15	130	95	65	45	16	2	4-∅14
DN20	150	105	75	58	18	2	4-∅14
DN25	160	115	85	68	18	2	4-∅14
DN32	180	140	100	78	18	2	4-∅18
DN40	200	150	110	88	18	3	4-∅18
DN50	230	165	125	102	18	3	4-∅18
DN65	290	185	145	122	18	3	4-∅18
DN80	310	200	160	138	20	3	8-∅18
DN100	350	220	180	158	20	3	8-∅18
DN125	400	250	210	188	22	3	8-∅18
DN150	480	285	240	212	22	3	8-∅22
DN200	600	340	295	268	24	3	12-∅22
DN250	730	405	355	320	26	4	12-∅26
DN300	850	460	410	378	28	4	12-∅26
DN350	980	520	470	438	30	4	16-∅30