

## BRASS SWING CHECK VALVE SCREWED END BSPT

**Model: ARV-1003SE**

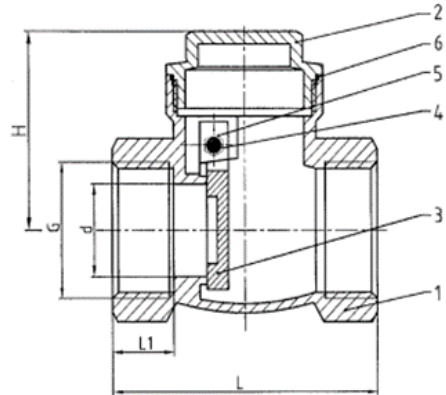

### TECHNICAL DATA

#### SPECIFICATION STANDARDS

Design according to: BS 5154

Threaded end according to BSPT Standard, ISO 228, BS21

Test and Inspection EN1266

Nominal pressure: 1.6 MPa

Test pressure shell: 2.4 MPa

Test pressure seal: 1.76 MPa

Working temperature: Max 100°C

Applicable medium: Water, Oil

#### STANDARD MATERIALS OF MAIN PARTS

ITEM	PART NAME	MATERIAL
1	BODY	BRASS
2	CAP	BRASS
3	DISC	BRASS
4	ROD	BRASS
5	HEX PLUG	BRASS
6	GASKET	PTFE

### DIMENSION (mm)

DN	L	L1	d	H
15	52.5	11.5	13.5	35.5
20	57	12.5	18	39.5
25	66	14	24	45.5
32	74	15.5	27	53.5
40	79.5	16.5	35.5	58
50	91.5	19	41	63
65 (PN10)	112	19	53	79
80 (PN10)	139	20	66	87
100 (PN10)	173	26	90	106